

BL-001

LONGITUDINAL BENDING STRESSES (PSI)

DESCRIPTION

1. FORE PEAK	0
2. DEEP TANK P/S	0
3. FWD STORES	6
4. FWD BUNKERS	1600
5. FWD COFFERDAM	0
6. #1 CARGO TANK	5229
7. #2 CARGO TANK	5193
8. #3 CARGO TANK	4229
9. #4 CARGO TANK	5116
10. BRIDGE CREW	3
11. BRIDGE STORES	12
12. BRIDGE F.W.	15
13. #5 CARGO TANK	2956
14. #6 BALLAST TANK	1628
15. #7 CARGO/BALLAST TANK	0
16. #8 CARGO/BALLAST TANK	0
17. #9 CARGO/BALLAST TANK	6012
18. #10 CARGO TANK	5417
19. #11 CARGO TANK	3257
20. AFT COFFERDAM	0
21. AFT BUNKERS	900
22. AFT SETTLERS	325
23. DISTILLED WATER	56
24. AFT STORES	75
25. AFT CREW	7
26. F.W. AFT	57
27. AFT PEAK	375

bl0001wm

This Study Guide Generated For Preview Only. Download the complete studyguide
 Here. <https://cgexams.seasources.net>

BL-002

LONGITUDINAL BENDING STRESSES (PSI)

DESCRIPTION

1. FORE PEAK	0
2. DEEP TANK P/S	0
3. FWD STORES	6
4. FWD BUNKERS	1600
5. FWD COFFERDAM	0
6. #1 CARGO TANK	5229
7. #2 CARGO TANK	5193
8. #3 CARGO TANK	4229
9. #4 CARGO TANK	5116
10. BRIDGE CREW	3
11. BRIDGE STORES	12
12. BRIDGE F.W.	15
13. #5 CARGO TANK	2956
14. #6 BALLAST TANK	1628
15. #7 CARGO/BALLAST TANK	0
16. #8 CARGO/BALLAST TANK	0
17. #9 CARGO/BALLAST TANK	6012
18. #10 CARGO TANK	5417
19. #11 CARGO TANK	3257
20. AFT COFFERDAM	0
21. AFT BUNKERS	900
22. AFT SETTLERS	325
23. DISTILLED WATER	56
24. AFT STORES	75
25. AFT CREW	7
26. F.W. AFT	57
27. AFT PEAK	375

bl0002wm

BL-003

LONGITUDINAL BENDING STRESSES (PSI)

DESCRIPTION

1. FORE PEAK	0
2. DEEP TANK P/S	0
3. FWD STORES	6
4. FWD BUNKERS	1600
5. FWD COFFERDAM	0
6. #1 CARGO TANK	5229
7. #2 CARGO TANK	5193
8. #3 CARGO TANK	4229
9. #4 CARGO TANK	5116
10. BRIDGE CREW	3
11. BRIDGE STORES	12
12. BRIDGE F.W.	15
13. #5 CARGO TANK	3956
14. #6 BALLAST TANK	1628
15. #7 CARGO/BALLAST TANK	5929
16. #8 CARGO/BALLAST TANK	6012
17. #9 CARGO/BALLAST TANK	0
18. #10 CARGO TANK	5417
19. #11 CARGO TANK	3257
20. AFT COFFERDAM	0
21. AFT BUNKERS	900
22. AFT SETTLERS	325
23. DISTILLED WATER	56
24. AFT STORES	75
25. AFT CREW	7
26. F.W. AFT	57
27. AFT PEAK	375

bl0003wm

BL-0004

LONGITUDINAL BENDING STRESSES (PSI)

DESCRIPTION

1. FORE PEAK	0
2. DEEP TANK P/S	0
3. FWD STORES	6
4. FWD BUNKERS	1600
5. FWD COFFERDAM	0
6. #1 CARGO TANK	5229
7. #2 CARGO TANK	5193
8. #3 CARGO TANK	4229
9. #4 CARGO TANK	5116
10. BRIDGE CREW	3
11. BRIDGE STORES	12
12. BRIDGE F.W.	15
13. #5 CARGO TANK	3956
14. #6 BALLAST TANK	1628
15. #7 CARGO/BALLAST TANK	5929
16. #8 CARGO/BALLAST TANK	6012
17. #9 CARGO/BALLAST TANK	0
18. #10 CARGO TANK	5417
19. #11 CARGO TANK	3257
20. AFT COFFERDAM	0
21. AFT BUNKERS	900
22. AFT SETTLERS	325
23. DISTILLED WATER	56
24. AFT STORES	75
25. AFT CREW	7
26. F.W. AFT	57
27. AFT PEAK	375

bl0004wm

BL-009

LONGITUDINAL BENDING STRESSES (PSI)

DESCRIPTION

1. FORE PEAK	0
2. DEEP TANK P/S	0
3. FWD STORES	6
4. FWD BUNKERS	1600
5. FWD COFFERDAM	0
6. #1 CARGO TANK	4659
7. #2 CARGO TANK	5280
8. #3 CARGO TANK	5489
9. #4 CARGO TANK	0
10. BRIDGE CREW	3
11. BRIDGE STORES	12
12. BRIDGE F.W.	10
13. #5 CARGO TANK	5196
14. #6 BALLAST TANK	2400
15. #7 CARGO/BALLAST TANK	5319
16. #8 CARGO/BALLAST TANK	5400
17. #9 CARGO/BALLAST TANK	6000
18. #10 CARGO TANK	5361
19. #11 CARGO TANK	4952
20. AFT COFFERDAM	0
21. AFT BUNKERS	850
22. AFT SETTLERS	360
23. DISTILLED WATER	50
24. AFT STORES	75
25. AFT CREW	7
26. F.W. AFT	57
27. AFT PEAK	0

bl0009wm

BL-0014

LONGITUDINAL BENDING STRESSES (PSI)

DESCRIPTION

1. FORE PEAK	0
2. DEEP TANK P/S	0
3. FWD STORES	6
4. FWD BUNKERS	1600
5. FWD COFFERDAM	0
6. #1 CARGO TANK	4659
7. #2 CARGO TANK	5280
8. #3 CARGO TANK	5489
9. #4 CARGO TANK	0
10. BRIDGE CREW	3
11. BRIDGE STORES	12
12. BRIDGE F.W.	10
13. #5 CARGO TANK	5196
14. #6 BALLAST TANK	2400
15. #7 CARGO/BALLAST TANK	5319
16. #8 CARGO/BALLAST TANK	5400
17. #9 CARGO/BALLAST TANK	6000
18. #10 CARGO TANK	5361
19. #11 CARGO TANK	4952
20. AFT COFFERDAM	0
21. AFT BUNKERS	850
22. AFT	360
23. DISTILLED WATER	50
24. AFT STORES	75
25. AFT CREW	7
26. F.W. AFT	57
27. AFT PEAK	0

bl0014wm

BL-0028

LONGITUDINAL BENDING STRESSES (PSI)		
	DESCRIPTION	
1.	FORE PEAK	0
2.	DEEP TANK P/S	0
3.	FWD STORES	6
4.	FWD BUNKERS	2867
5.	FWD COFFERDAM	0
6.	#1 CARGO TANK	3596
7.	#2 CARGO TANK	3996
8.	#3 CARGO TANK	4128
9.	#4 CARGO TANK	4146
10.	BRIDGE CREW	0
11.	BRIDGE STORES	0
12.	BRIDGE F.W.	0
13.	#5 CARGO TANK	0
14.	#6 BALLAST TANK	0
15.	#7 CARGO/BALLAST TANK	1821
16.	#8 CARGO/BALLAST TANK	2328
17.	#9 CARGO/BALLAST TANK	2303
18.	#10 CARGO TANK	4042
19.	#11 CARGO TANK	3798
20.	AFT COFFERDAM	0
21.	AFT BUNKERS	850
22.	AFT SETTLERS	340
23.	DISTILLED WATER	60
24.	AFT STORES	80
25.	AFT CREW	7
26.	F.W. AFT	70
27.	AFT PEAK	0

bl0028_wm_090622

Standard Hand Signals For Controlling Crane Operations

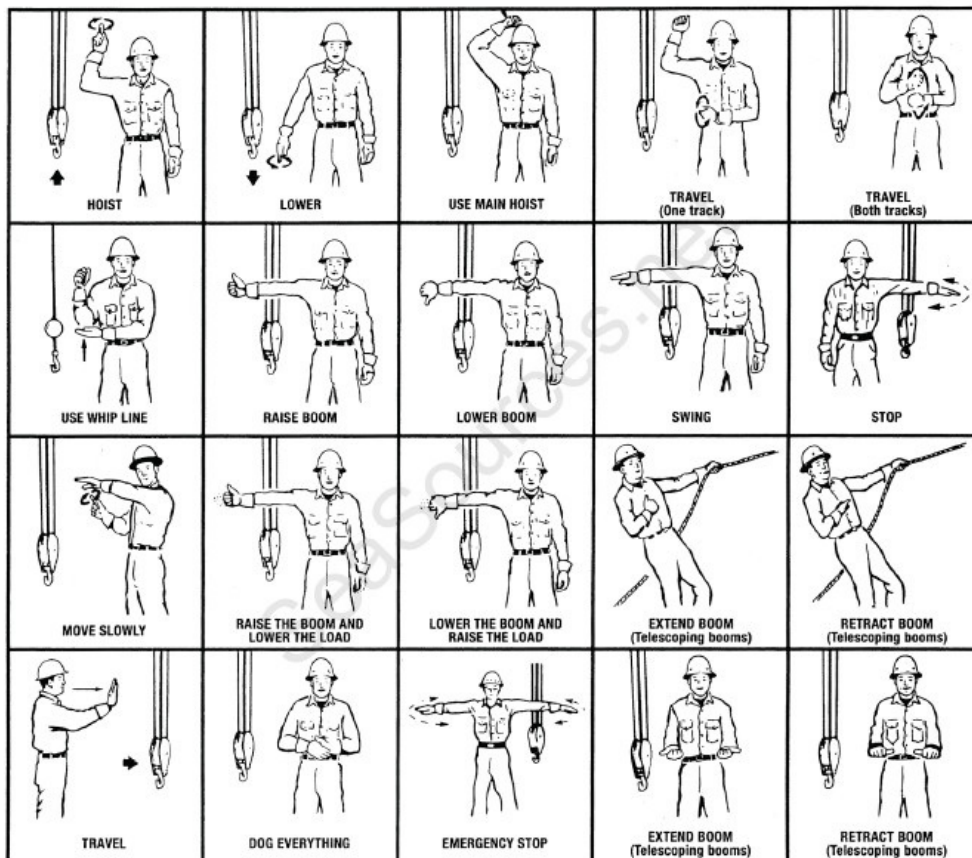

cranesignal_wm

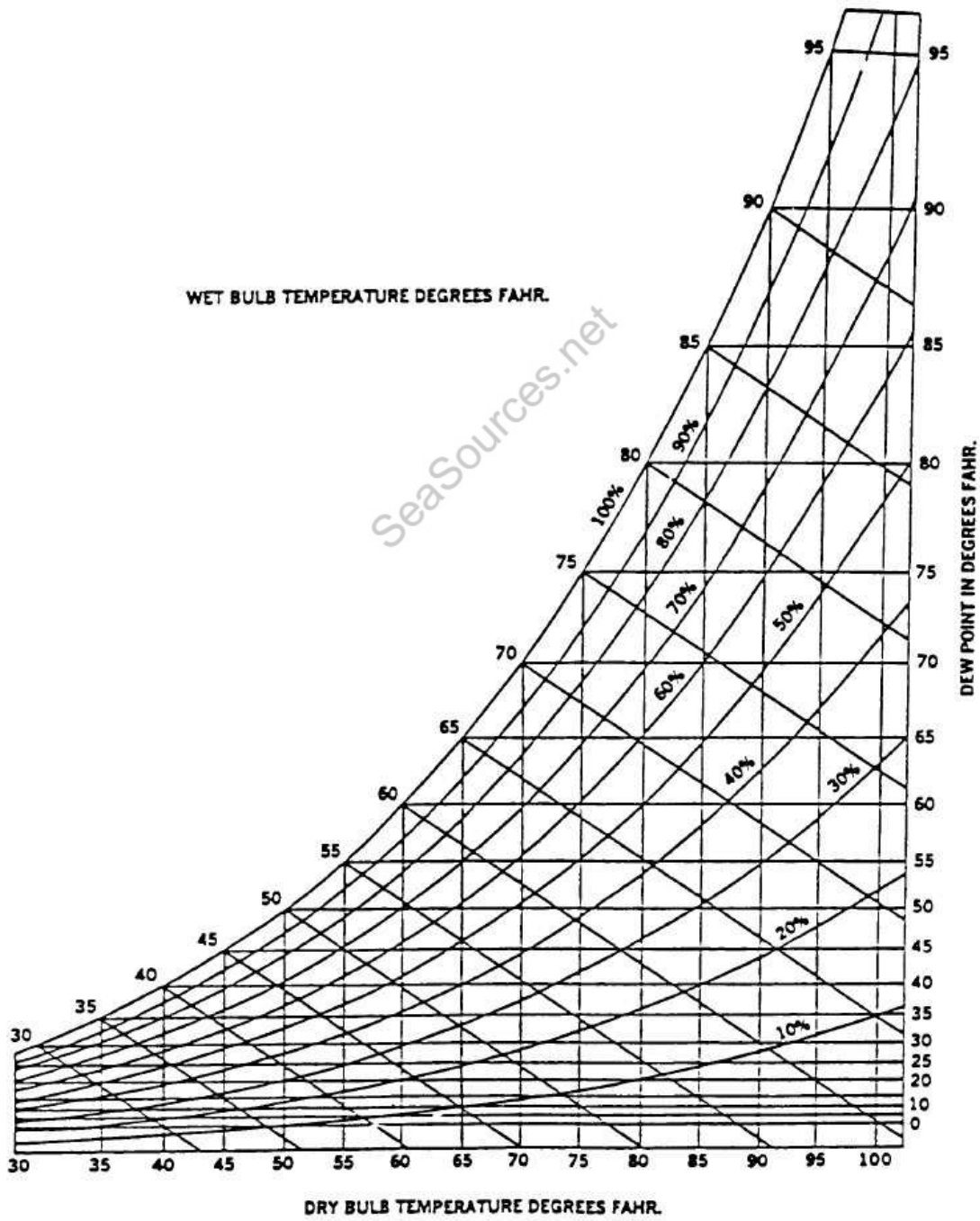

D008DG

d008dg_wm_012814



D023DG



d023dg_wm_072420

D045DG

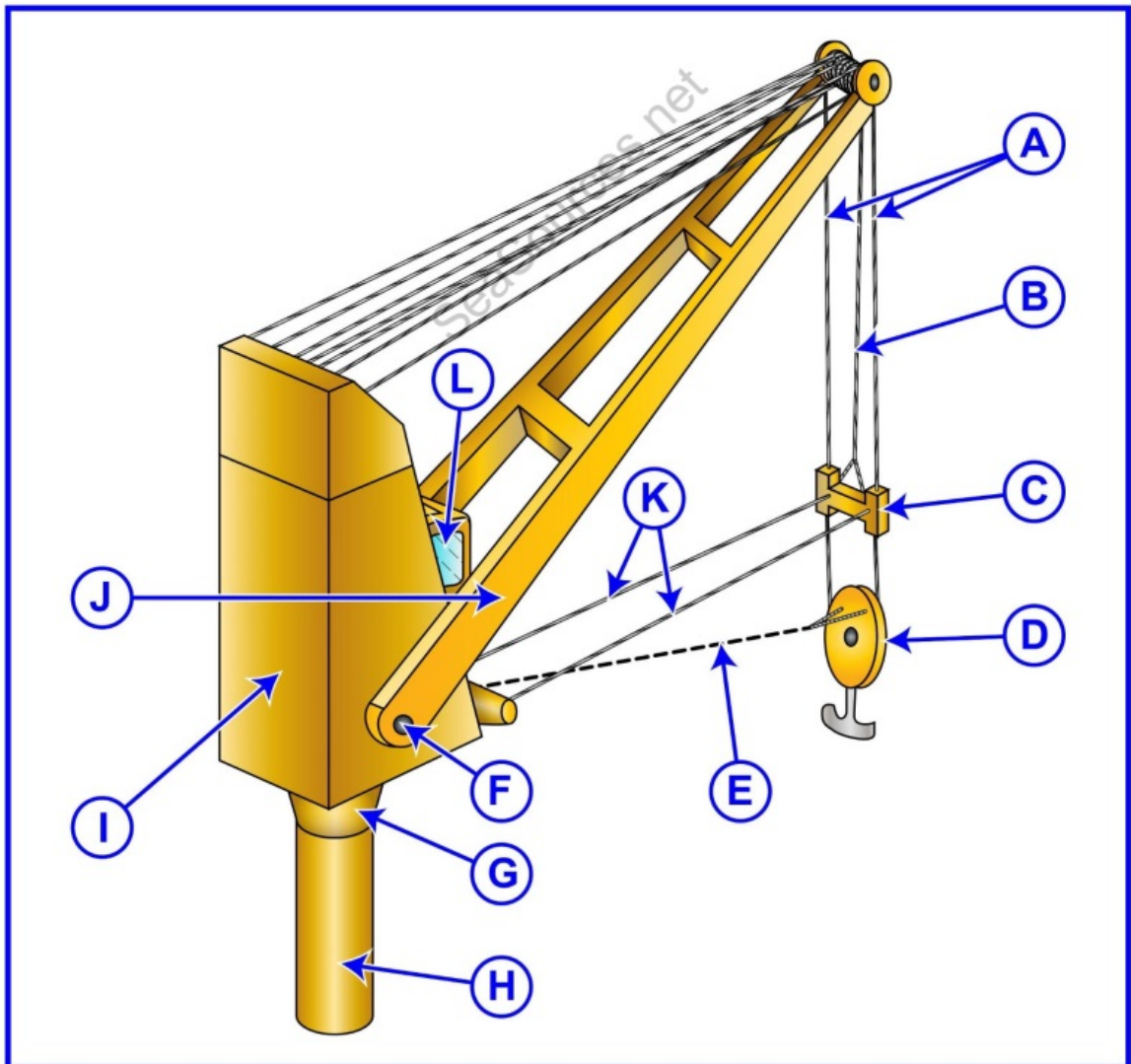

d045dg_wm_082918

D051DG

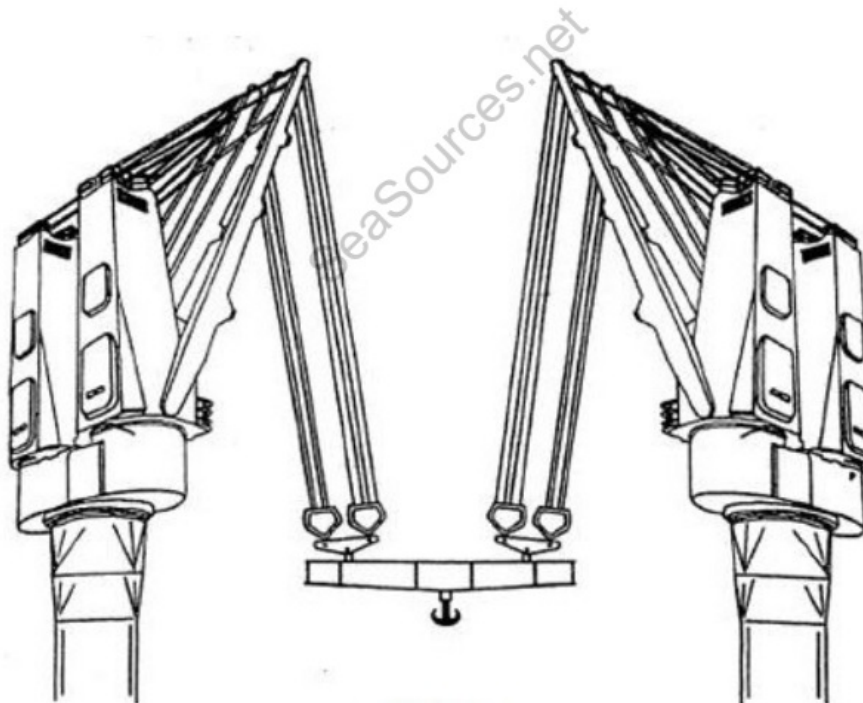

d051dg_wm_052316

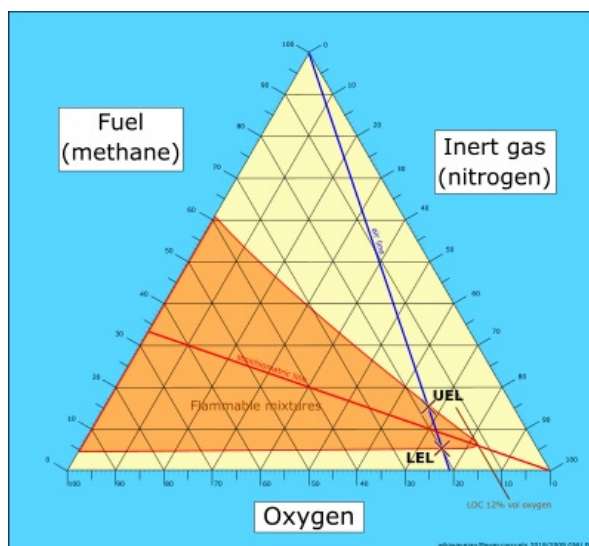

flammability diagram

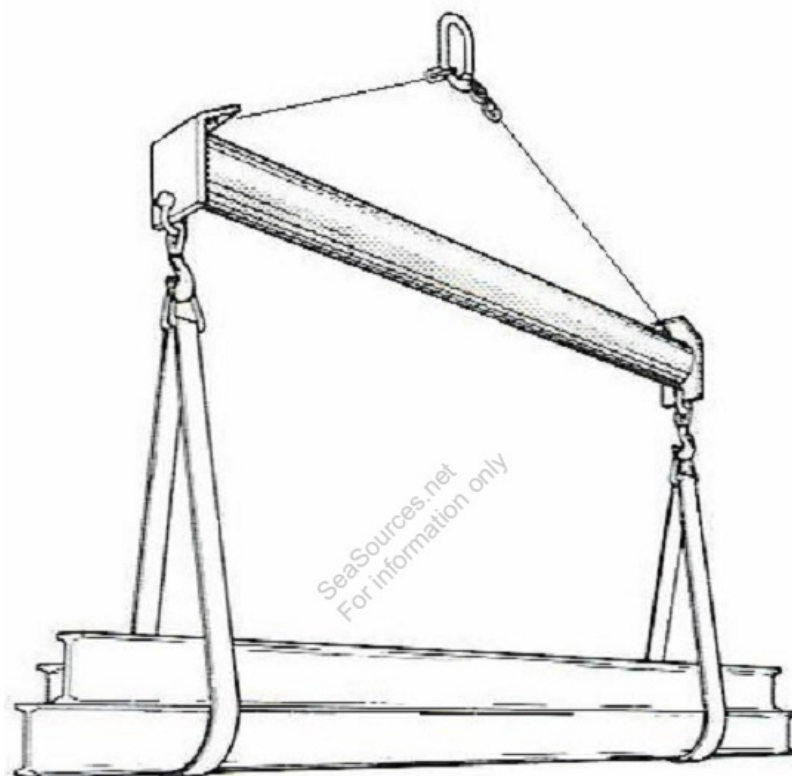

spreaderbar_wm