

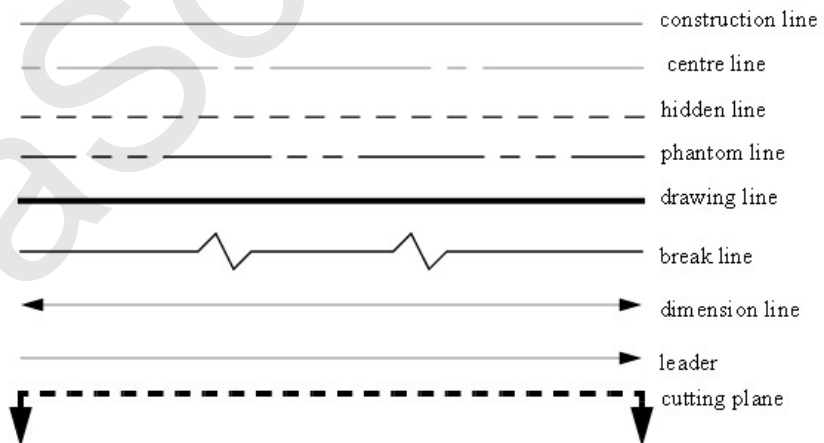

3jawuniversalchuck



4jawindependentchuck



draftinglines

EL-0066

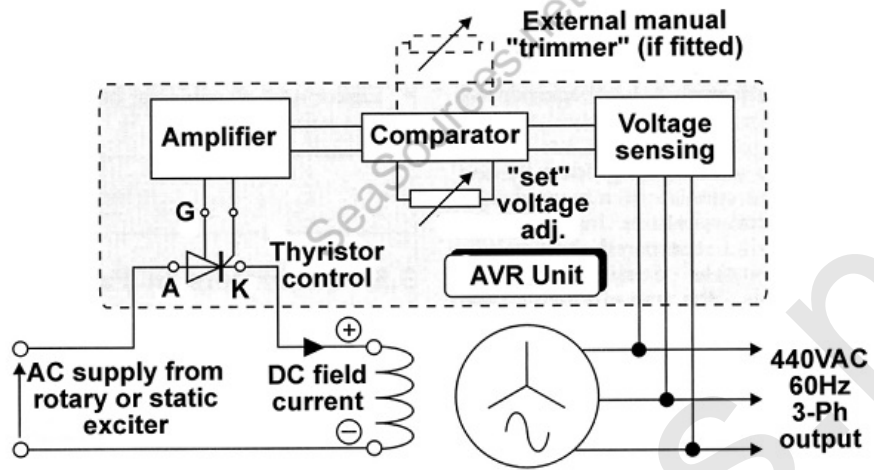

A

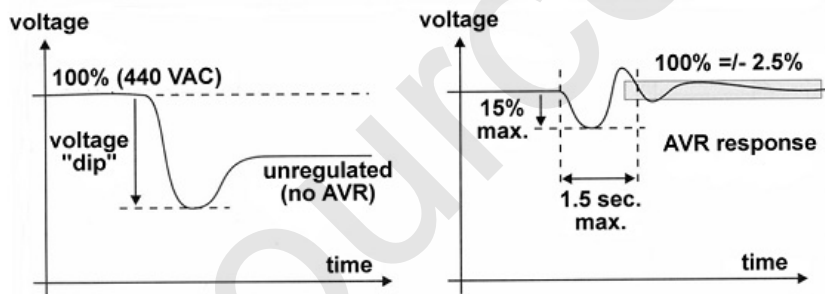

B

EL-0094

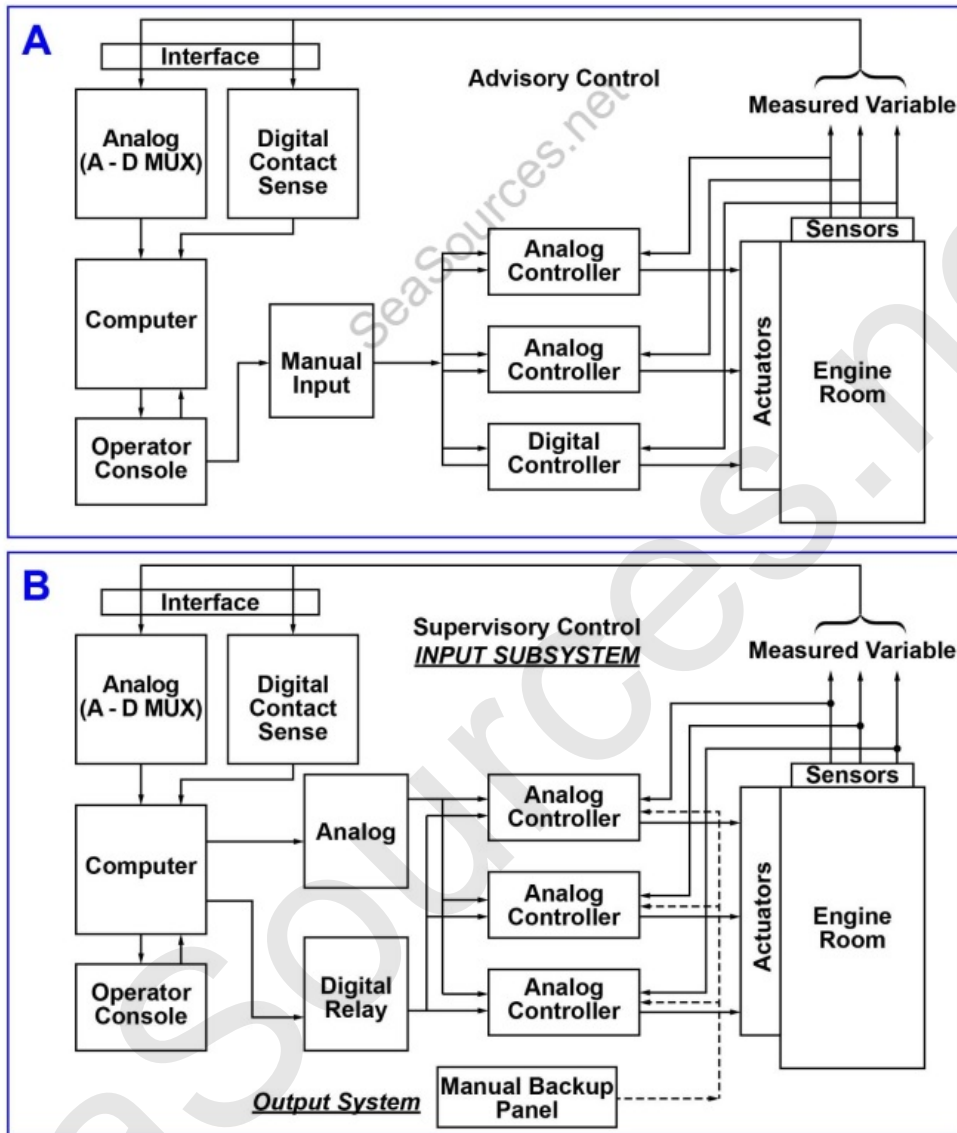

el0094\_wm\_100918

EL-0095

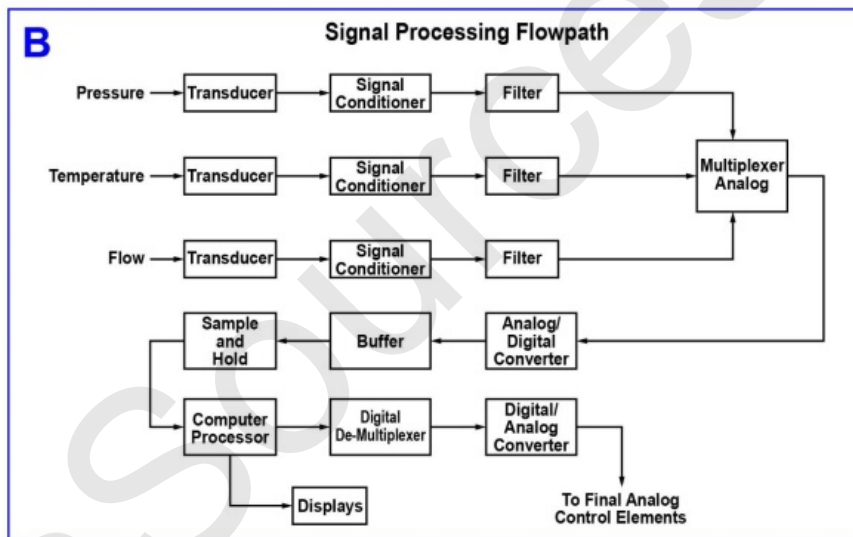
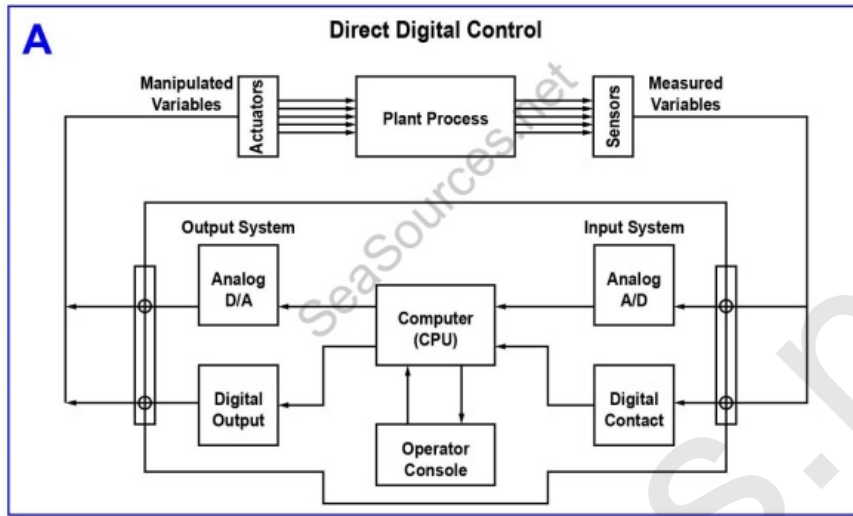

eI0095\_wm\_100918

EL-0096

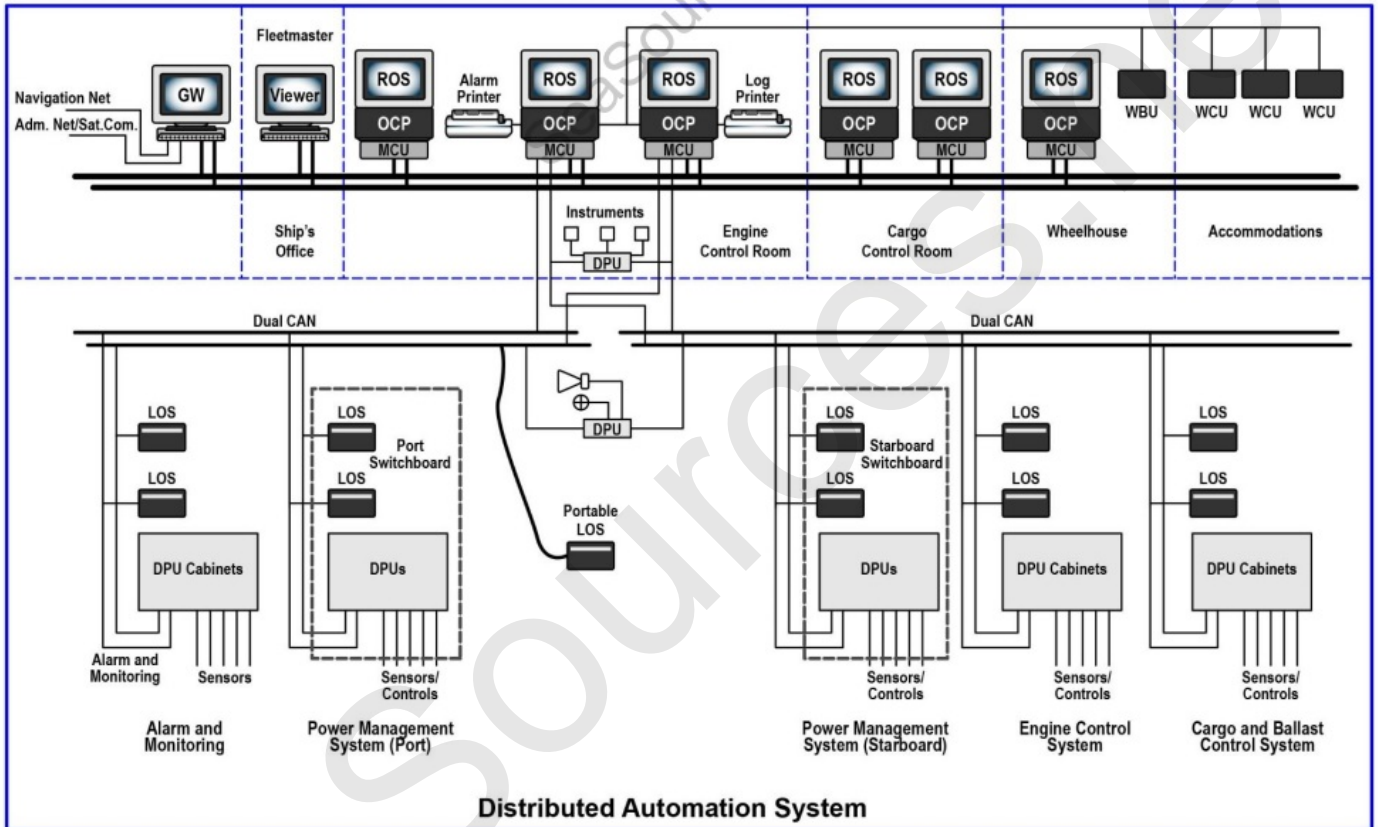

eI0096\_wm\_100918

**EL-0124**  
**Signal Cabling Circuit**

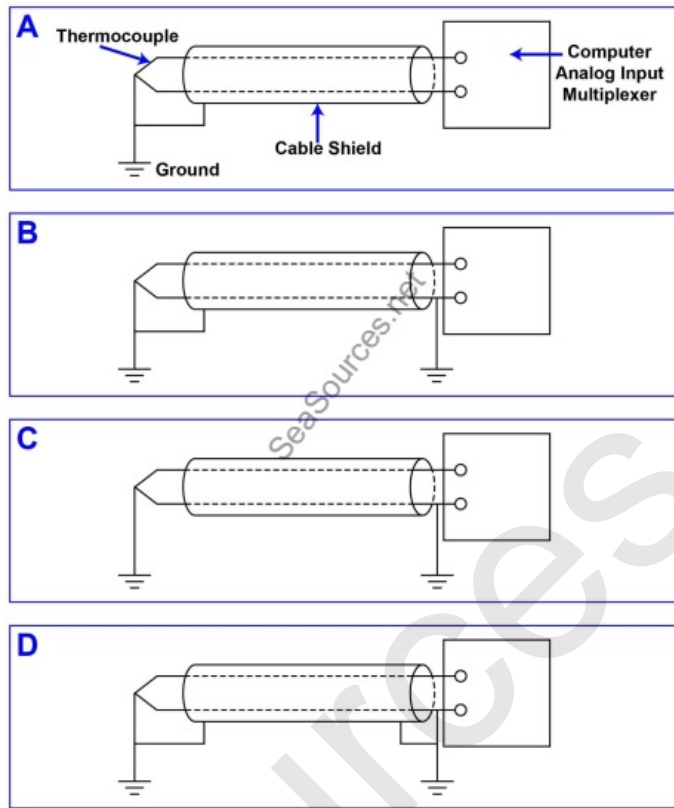

el0124\_wm\_100918

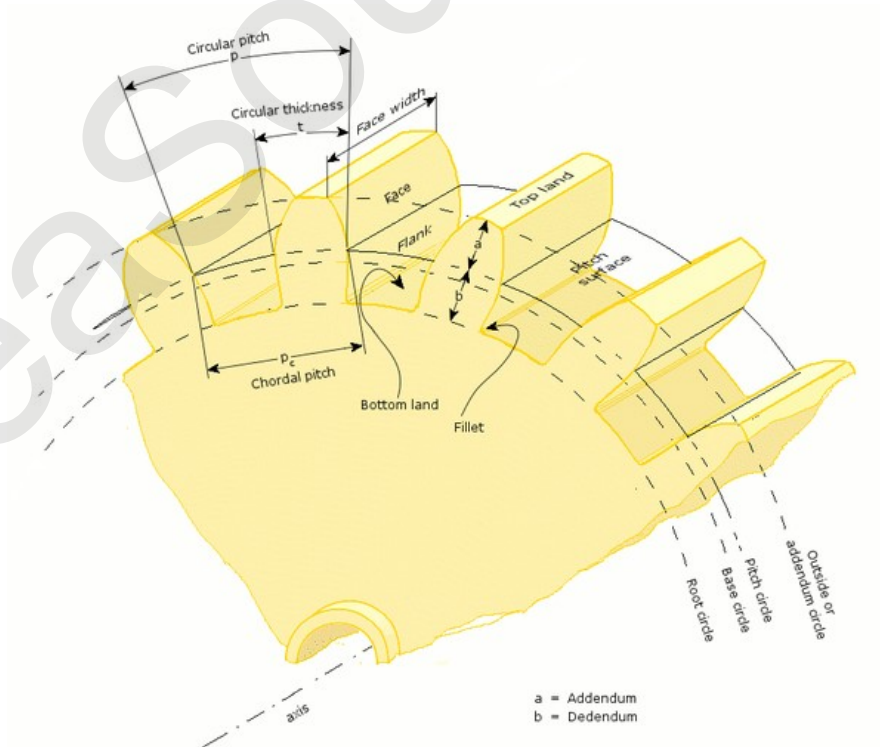

geardiagram

GS-0001

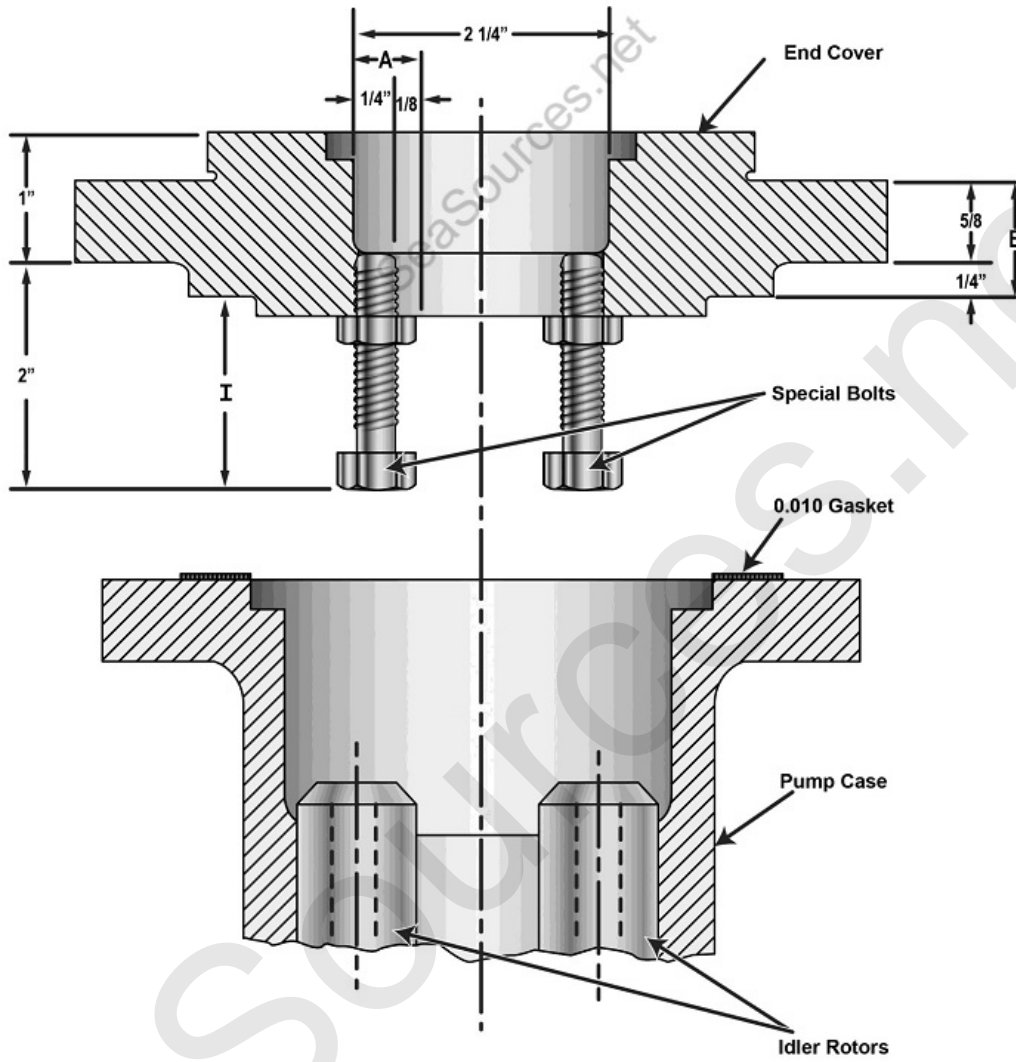

gs0001\_a0\_082815wm

GS-0002

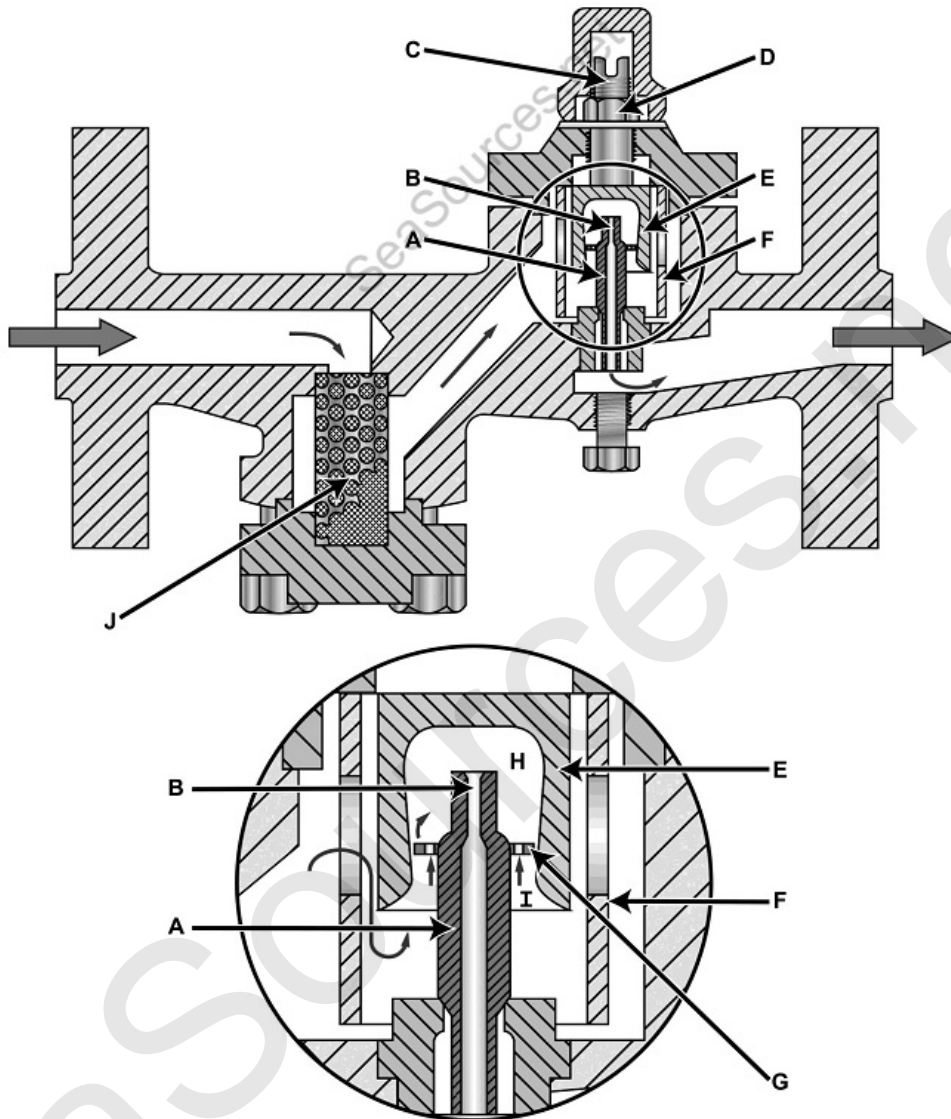

gs0002\_a0\_083115wm



GS-0003

Top View

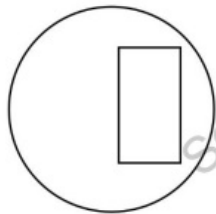

Front View

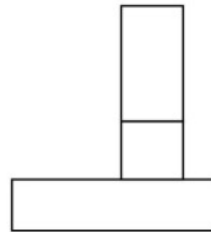

Possible Right Side View

1

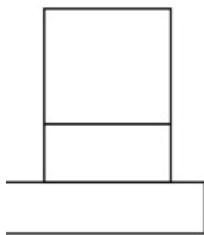

2

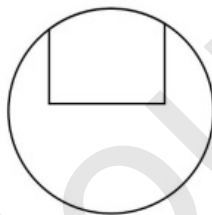

3

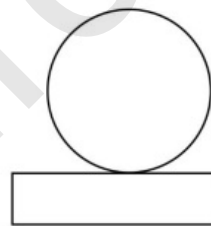

4

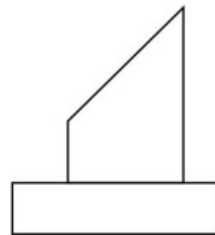

GS-0005

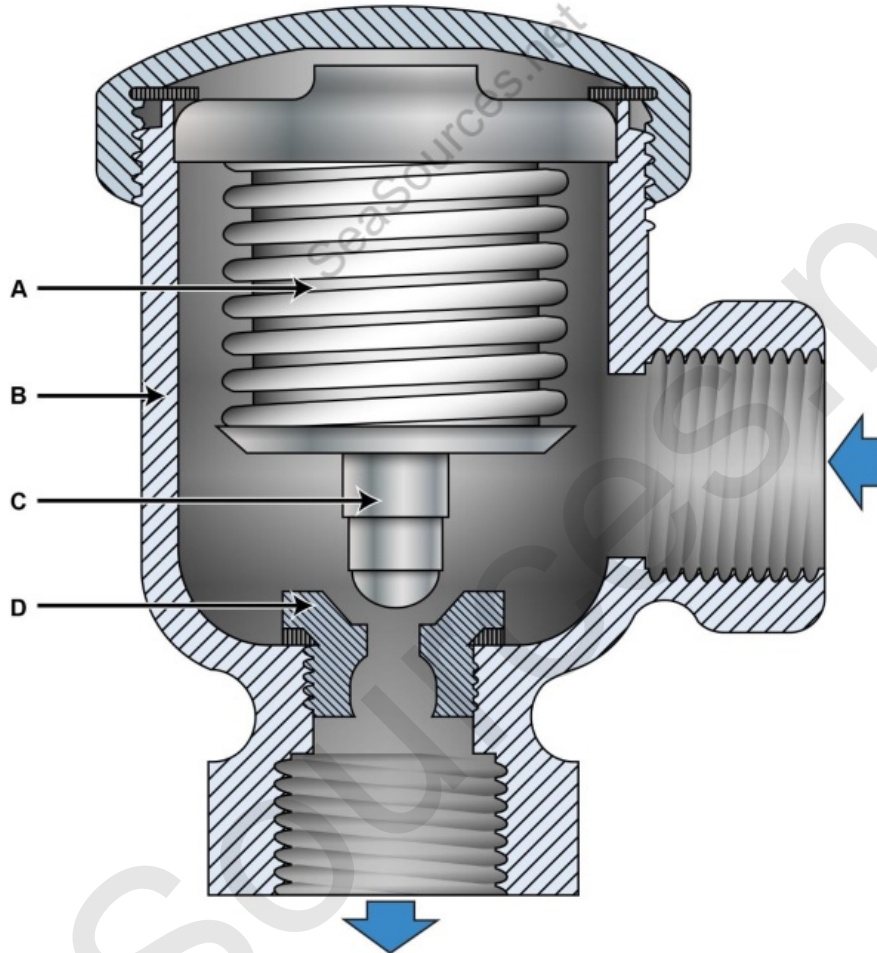

gs0005\_a0\_092118wm

GS-0006

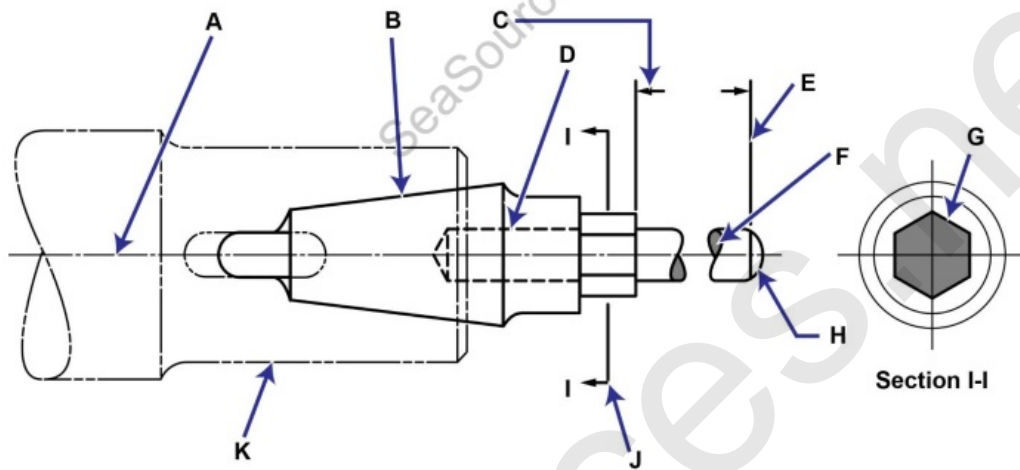

gs0006\_wm\_092118

GS-0007

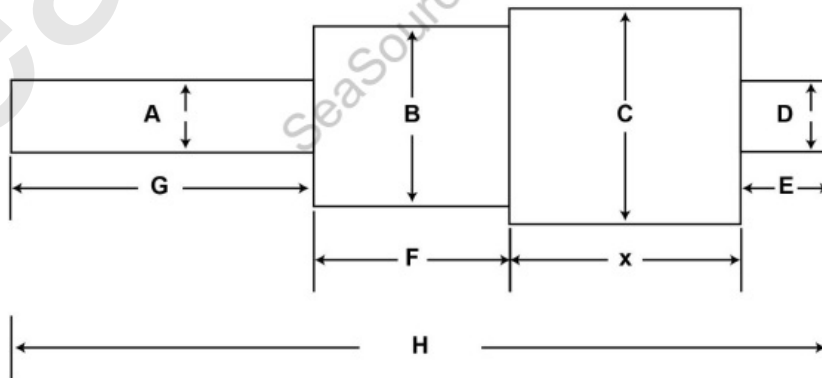

gs0007\_wm\_092118

GS-0008

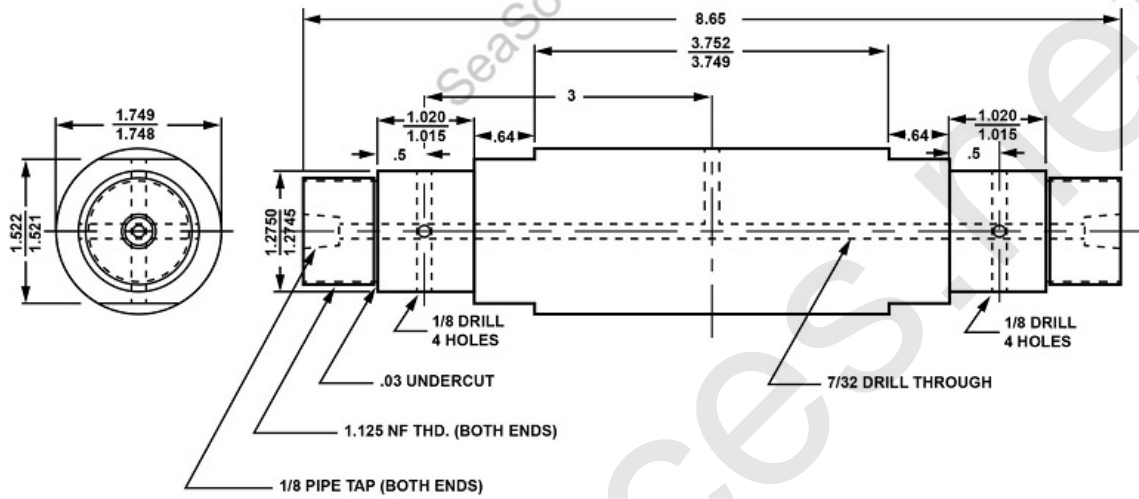

DET -- 56 --SHAFT  
 6 -- TYPE SAE 1095 STEEL  
 STK 2 DIA WT 7.92 LBS.  
 HARDEN -- ROCKWELL 52-64  
 GRIND  
 SCALE: 2/3 = 1

gs0008\_ao\_090315wm

GS-0009

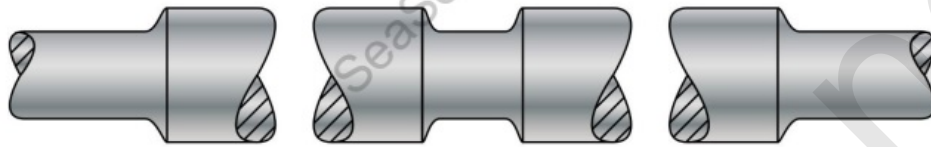
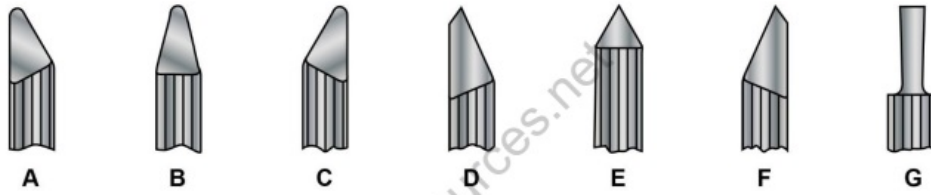

Fig. I

Fig. II

Fig. III

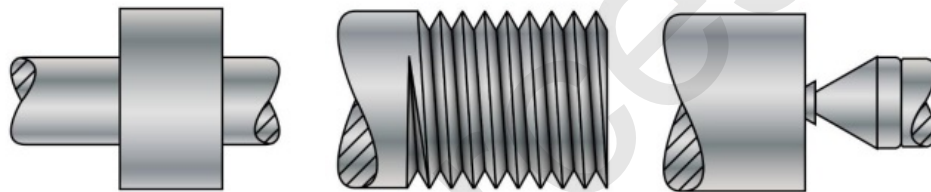

Fig. IV

Fig. V

Fig. VI

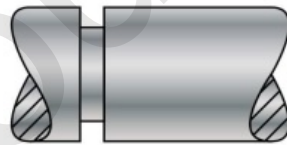
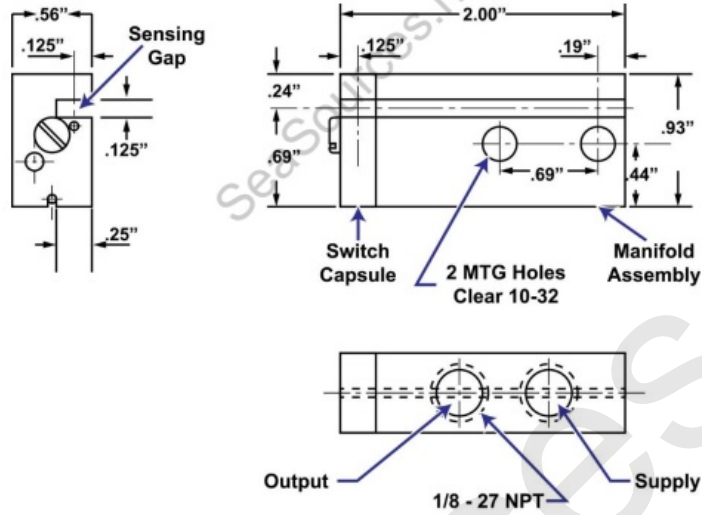

Fig. VII

GS-0010



Left Hand Limit Sensor Assembly

gs0010\_wm\_092118

GS-0011

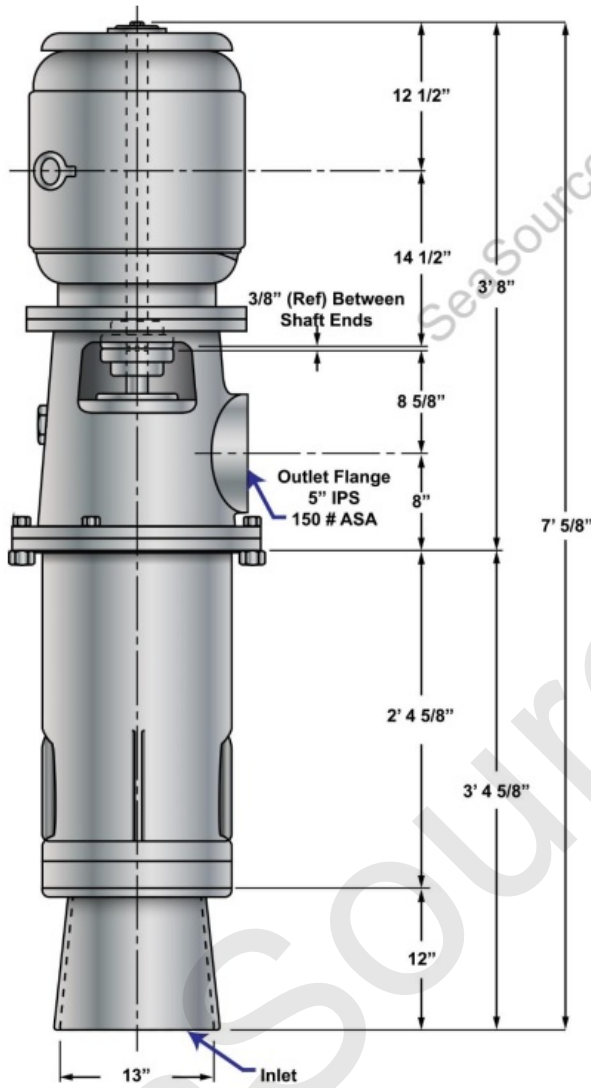

**MOTOR CHARACTERISTICS**

Motor (A. C.)	Electro Dynamic
Rating H. P.	25
Speed R. P. M. (SYN.)	1200
Frame	365 VY
Type	TN
Volts	440
Cycles	60
Phase	3

**PUMP CHARACTERISTICS**

Capacity G. P. M.	400
Speed R. P. M.	1150
Suction Lift "HG	10
B, H, P. @ 1200 SSU-75° F	24.9
Oil viscosity Range, SSU	74-7000
Viscosity Normal SSU @ 140° F	155
Discharge Normal PSIG	55
Fluid Handled, Lube Oil	2190 TEP.
Navy Specification	MIL-L-17331
Oil Temperature Range ° F	40-180

Illustration scale: 1" = 1'

gs0011\_wm\_092118

GS-0012

ITEM	QTY	DESCRIPTION	MATERIAL	REMARKS
1	1	Impeller	NI-CU Alloy	3H1A
2	1	Volute	Gunmetal	3H4C
3	1	Suction Cover	Gunmetal	3H193
4	1	Volute Wear Ring	Valve Bronze	A-3H180A
5	1	Volute Gasket	PTFE/ Glass Fiber Reinforced	P/N 3H37
6	1	Impeller Wear Ring	NI-CU Alloy	3H180
7	1	Motor Bracket	Cast Steel	2L3C
8	1	Shaft Sleeve	NI-CU Alloy	P/N A-014-20A-0-01
9	1	Throat Bushing	NI-CU Alloy	P/N 4L26-4
10	1	Lantern Ring	NI-CU Alloy	4L169
11	2	Gland Half	Bronze	B-017-5AH-A
12	1	Slinger	Neoprene	1 47/64 X 3 3/4 X 1/8TH
13	1	Impeller Washer	NI-CU Alloy	17/32 X 9/16 X 3/16TH
14	1	Impeller Key	NI-CU Alloy	1/4 SQ X 2 5/16 TH
15	1	SKT HD Capscrew	SST	1/2-13 NC X 1 1/4 LG NYLOCK
16	5	Packing Rings	Plastic Metallic	1 3/4 X 2 5/8 X 7/16 SQ
17	1	Name Plate	Brass	P/N A-226-00N-0-03
18	8	Hex Head Capscrews	NI-CU Alloy	1/2-13 NC X 1 LG
19	4	Hex Head Capscrews	NI-CU Alloy	3/8-16 x 1 LG
20	4	Hex Head Capscrews	NI-CU Alloy	1/2-13 NC X 1 1/4 LG
21	2	Stud	SST	3/8-16 NC X 2 1/2 LG
22	2	Hex Nut	Bronze	3/16-16 2
23	3	Setscrew	NI-CU Alloy	10-24 NC X 1/4 LG CUP
24	3	Setscrew	NI-CU Alloy	10-24 NC X 1/4 LG CUP
25	4	Drive Screw	Brass	6-24 X 1/4 LG
26	3	Pipe Plug	Bronze	1/4 NPT
27	1	Vent Valve	Bronze	1/4 NPT
28	1	O Ring	Buna "N"	1 5/16 ID 1/16 WIDE
29	1	Pipe	70-30 CU-NI	4 11/16 LG 1/4 NPT
30	1	Pipe	70-30 CU-NI	3 3/16 LG 1/4 NPT
31	1	Flange	Valve Bronze	1/4 INCH 150#

Note: Inside dia. of Wearing Ring, PC No. (4) is .020 undersize outside dia. of Wearing Ring, PC No. (6) is .020 oversize when finished as repair parts and are designated as part No. 5 A3H180A-1 U/S and 3H180-1 O/S

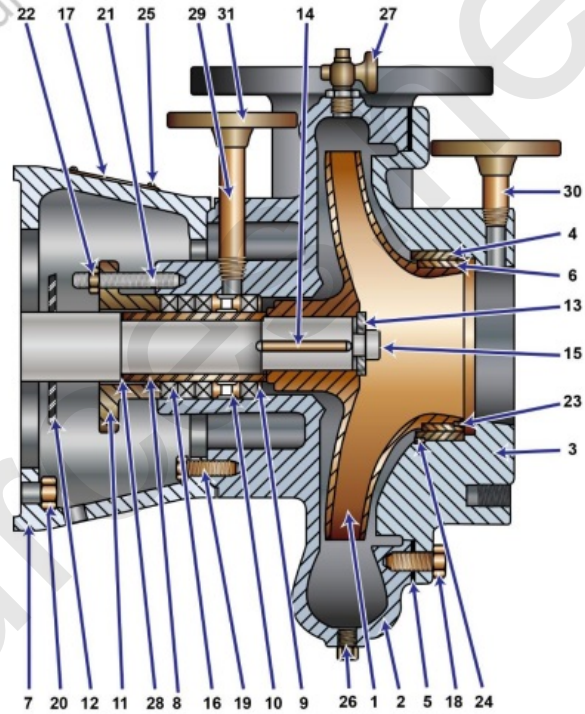



GS-0015

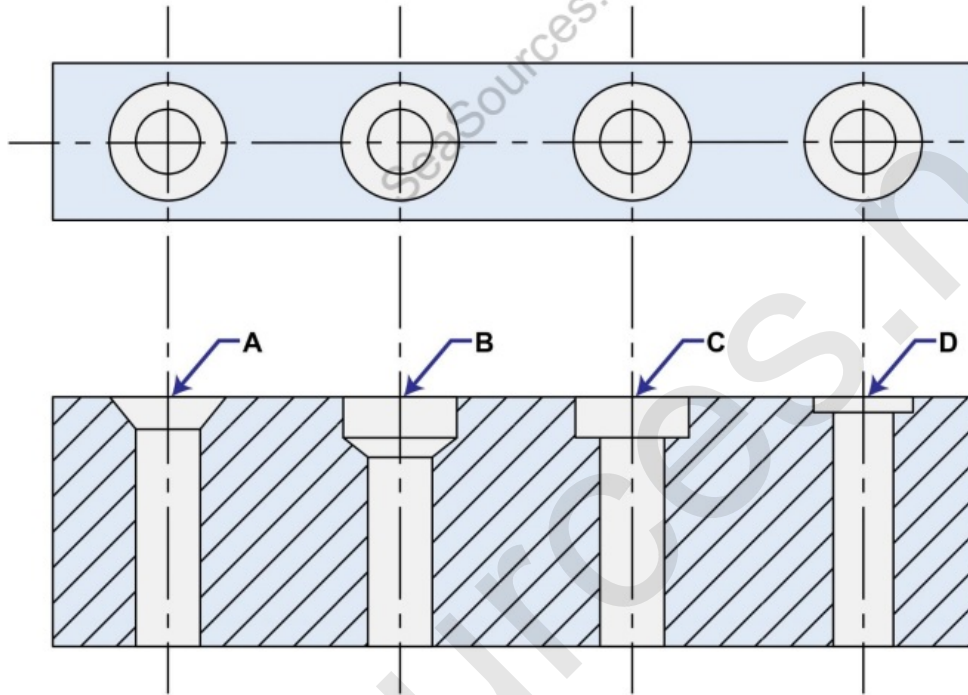

gs0015\_wm\_092418

GS-0019

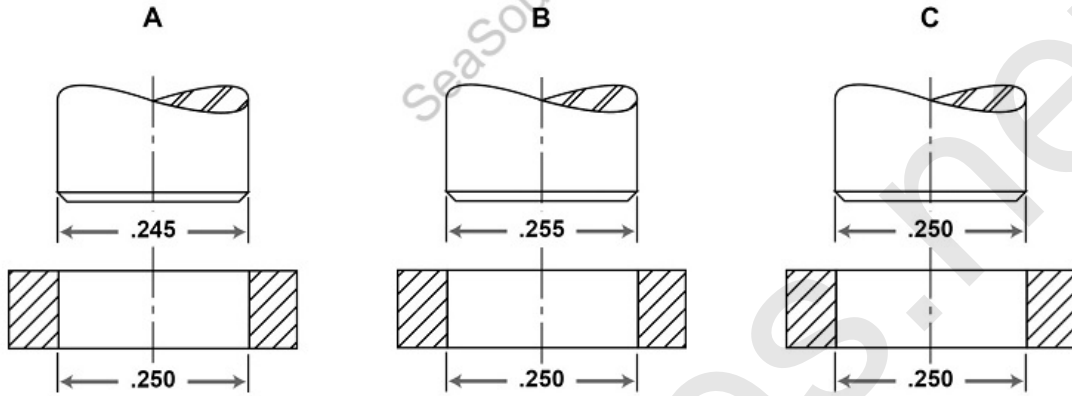

gs0019\_a0\_091815wm

GS-0021

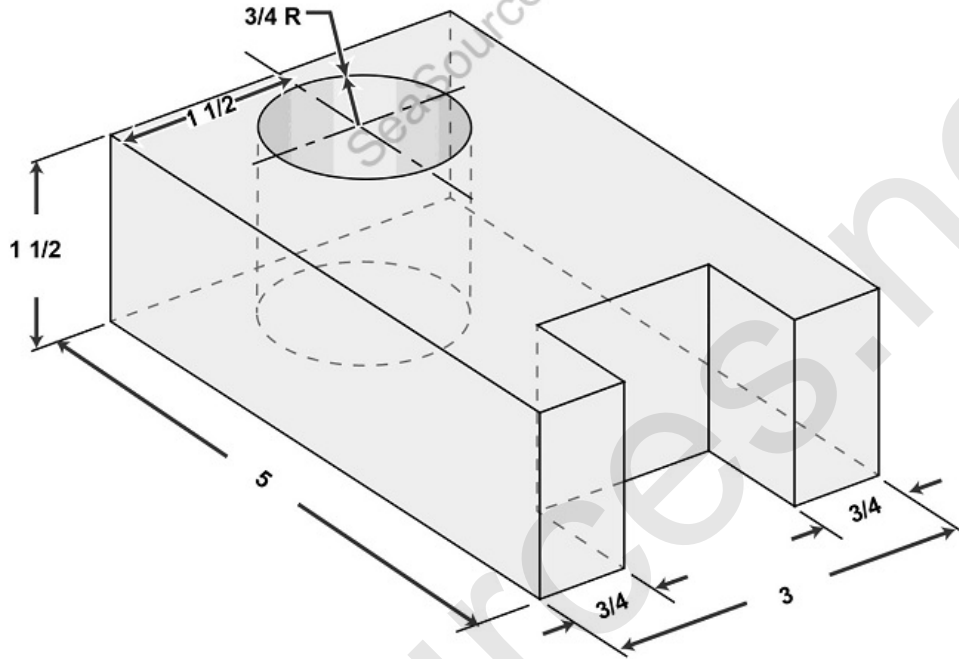

gs0021\_a0\_092215wm

GS-0022

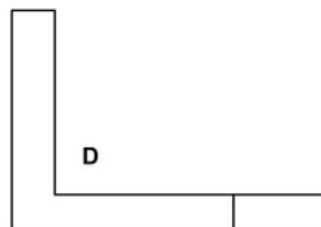
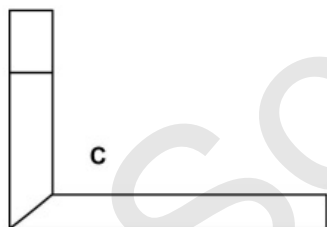
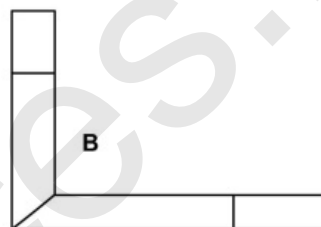
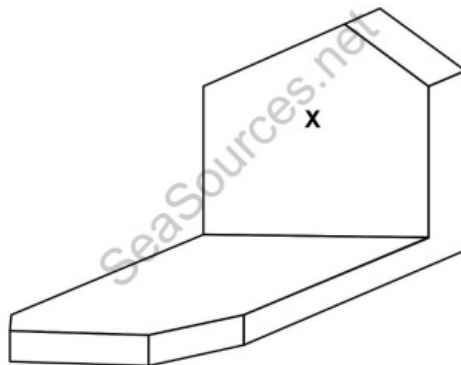

gs0022\_wm\_092418